

KOTHARI INTERNATIONAL SCHOOL, NOIDA
HALF YEARLY EXAMINATION , SESSION 2025-2026

GRADE: 7 SUBJECT: MATHEMATICS
SET: A SECTION B (SUBJECTIVE)

DAY & DATE : TUESDAY, 9th SEPTEMBER 2025

MAXIMUM MARKS: 60

TIME ALLOTTED: 2 HOURS 30 MINUTES

NAME: _____

ROLL NO: _____

GENERAL INSTRUCTIONS:

1. This question paper consists of 4 pages and 22 questions. All questions are compulsory.
2. The paper contains three type of questions
 - Q. No.1 to 11 are of 2 marks each.
 - Q. No.12 to 17 are of 3 marks each.
 - Q. No. 18 to 22 are of 4 marks.
3. Read the question paper carefully and then attempt it.

SECTION B

Q1. Are the rational numbers $\frac{-8}{28}$ and $\frac{32}{72}$ equivalent? Justify your answer. **(2)**

Q2. Convert the following equations in statement form : **(2)**

(a) $\frac{m}{5} - 12 = 58$

(b) $7n + 15 = 29$

Q3. Fill in the blank with correct symbol $>$, $=$ or $<$. Justify your answer. **(2)**

$\frac{-7}{8}$ _____ $\frac{-8}{10}$

Q4. Simplify the following using the suitable property : **(2)**
 $26 \times (-480) + (-480) \times (-36)$

Q5. If $k + 7 = 16$, then what is the value of $8k - 72$? **(2)**

Q6. In the given figure, find the value of $\angle AOC$. **(2)**

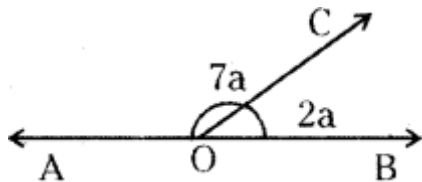

Q7. Evaluate : **(2)**

(a) $1256.4 \div 100$

(b) 156.5×100

Q8. The mode of the given data is 12. Find the value of x. **(2)**

10,12, x+2,11,12,13,14,14,10

Q9. (a) Write the next two rational numbers to complete the pattern: (2)
 $\frac{-8}{7}, \frac{-16}{14}, \frac{-24}{21}, \frac{-32}{28}, \text{---}, \text{---}$

(b) The standard form of $\frac{12}{-24}$ is _____

Q10. Find the median of the given data: (2)
 24, 36, 46, 17, 18, 25, 35

Q11. A square and an equilateral triangle have a side in common. If side of triangle is $\frac{4}{3}$ cm long, (2)
 find the perimeter of figure formed.

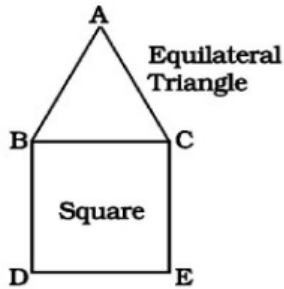

SECTION C

Q12. In the given figure, $l \parallel m$ and $p \parallel q$. Find the value of x , t and z . Give reasons for your answer. (3)

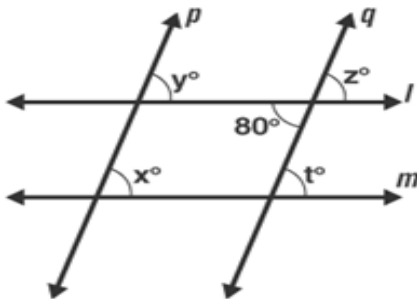

Q13. The ages (in years) of 10 teachers of a school are :
 32, 41, 28, 54, 35, 26, 23, 33, 38, 40
 (i) What is the mean age of these teachers? (2)
 (ii) What is the age of the oldest teacher and that of the youngest teacher? (1)

Q14. In the given figure, $l \parallel m$ and a transversal t intersects these lines at P and Q respectively. Find the value of $2a + b$. (3)

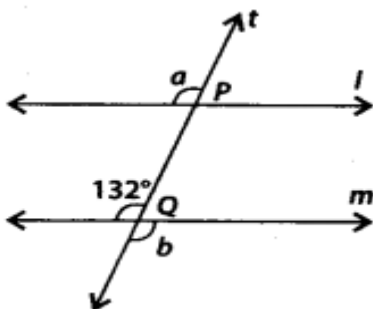

- Q15. (a) Verify the following : (2)
 $(-18) \times [(-4) - (6)] = [(-18) \times (-4)] - [(-18) \times (6)]$
 (b) Identify and write the name of the property used in part(a) (1)
- Q16. If the product of two rational numbers is $\frac{-9}{16}$ and one of them is $\frac{-4}{15}$, find the other number. (3)
- Q17. The sum of three consecutive even numbers is 42. Find the numbers. (3)

SECTION D

- Q18. A fruit merchant earns a profit of Rs. 6 per bag of oranges sold and a loss of Rs.4 per bag of grapes sold.
 a) Merchant sells 1800 bags of oranges and 2500 bags of grapes. What is the profit or loss? (1)
 b) What is the number of bags of oranges to be sold to have neither profit nor loss if the number of bags of grapes sold is 900 ? (3)

- Q19. (a) In the given figure, determine whether line a is parallel to line b. (2)
 Give reason to support your answer.

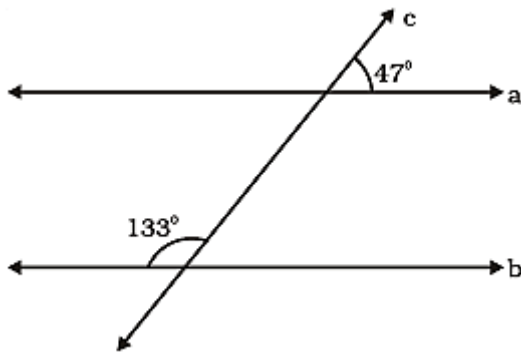

- (b) Arrange the following rational numbers in ascending order : (2)
 $\frac{-7}{8}, \frac{-3}{4}, \frac{-5}{6}$

- Q20. (a) In a hurdle race, Nidhi is over hurdle B and $\frac{2}{6}$ of the way through the race, as shown in the given figure. Then, answer the following questions:

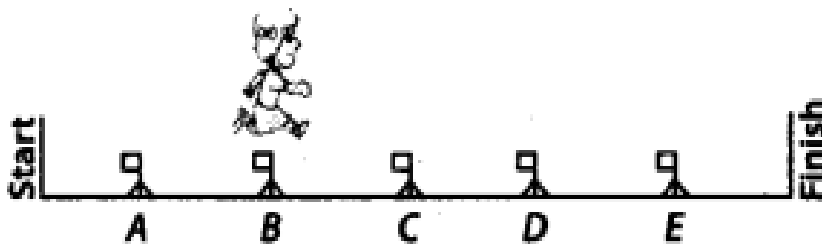

- (i) Where will Nidhi be when she is $\frac{5}{6}$ of the way through the race? (1)
 (ii) What part of the race has Nidhi finished when she is over hurdle C. (1)
- (b) A car can cover a distance of 80.5 km in 2.5 hours. How much will it travel in 1 hour with same speed ? (2)

Q21. (a) In an isosceles triangle, the base angles are equal. The vertex angle is 50° . What are the base angles of the triangle? (3)

(b) Sum of two numbers is 81. One is twice the other. (1)
The equation formed is _____

Q22. The students of Class VII have to choose one club from Music, Dance, Yoga, Dramatics, Fine arts and Electronics clubs. The data given below shows the choices made by girls and boys of the class. Study the table and answer the questions that follow:

| CLUBS | GIRLS | BOYS |
|--------------------|--------------|-------------|
| MUSIC | 15 | 12 |
| DANCE | 24 | 16 |
| YOGA | 10 | 8 |
| DRAMATICS | 19 | 17 |
| FINE ARTS | 27 | 11 |
| ELECTRONICS | 21 | 30 |

(a) Draw a double bar graph using an appropriate scale to depict the above data. (3)

(b) Which is the most preferred club by boys? (1)